



VARIOUS PATENTS APPLY

# Priming Assisted Centrifugal Pump w/Autostart

## Model PA12A60-B-C6.6 /S1

### Size 12" x 12"



Total Head		Capacity of Pump in U.S. Gallons per Minute (GPM) at Continuous Performance				
P.S.I.	Feet					
45.1	104	1100	1100	1100	1100	1100
43.4	100	2000	2300	2300	2300	2300
39.0	90	2700	3620	3750	3750	3750
34.7	80	3010	4120	4650	4700	4700
30.4	70	3090	4250	5050	5200	5430
26.0	60	3150	4300	5100	5710	5900
22.7	50	3200	4350	5150	5810	6040
17.3	40	3290	4400	5200	5900	6100
13.0	30	3350	4450	5250	5910	6190
8.7	20	3400	4500	5300	5920	6320
<b>Suction Lift</b>		<b>25'</b>	<b>20'</b>	<b>15'</b>	<b>10'</b>	<b>5'</b>

**PUMP SPECIFICATIONS**

**Size:** 12" x 12" (305 mm x 305 mm) Flanged.  
**Casing:** Gray Iron 30.  
 Maximum Operating Pressure 71 psi (490 kPa).  
**Enclosed Type, Three Vane Impeller:** Ductile Iron 60-40-18.  
 Handles 3" (76.2 mm) Diameter Spherical Solids.  
**Impeller Shaft:** Stainless Steel 17-4 PH.  
**Replaceable Wear Rings:**  
 Impeller - Ductile Iron 80-60-03.  
 Suction Head - Copper Alloy C93200.  
**Seal Plate:** Gray Iron 30.  
**Bearing Housing:** Gray Iron 30.  
**Seal:** Mechanical, Oil-Lubricated, Double Floating, Self-Aligning.  
 Silicon Carbide Rotating and Stationary Faces. Stainless Steel 316 Stationary Seat. Buna-N and Fluorocarbon Elastomers (DuPont Viton® or Equivalent). Stainless Steel 18-8 Cage and Spring.  
 Maximum Temperature of Liquid Pumped 160°F (71°C).  
**Shaft Sleeve:** Stainless Steel 304.  
**Priming Chamber:** Gray Iron 30 Housing w/Stainless Steel Float and Linkage.  
**Discharge Check Valve:** Ductile Iron Housing w/Buna-N Flapper.  
**Radial Bearing:** Single Row Roller.  
**Thrust Bearings:** Two Open Single Row Ball.  
**Bearing and Seal Cavity Lubrication:** SAE 30 Non-Detergent Oil.  
**Flanges:** Gray Iron 30.  
**Gaskets:** Vegetable Fiber, Buna-N, Resistant Synthetic Rubber and Cork.  
**O-Rings:** Buna-N and Neoprene.  
**Hardware:** Standard Plated Steel.  
**Bearing and Seal Cavity Oil Level Sight Gauges.**  
*\*Consult Factory for Applications Exceeding Maximum Pressure and/or Temperature Indicated.*  
**Standard Equipment:** High Speed (55 MPH/89 KM/H) Tandem Axle Pneumatic-Tired Wheel Kit w/DOT-Approved Lights and Electric Brakes. Battery. Gear-Driven Air Compressor. Hoisting Bail. Skid Base. Strainer. Single Ball Type Float Switch.  
**\*\*50 Ft. (15 m) Standard Length.**



**WARNING!**  
Do not use in explosive atmosphere or for pumping volatile flammable liquids.

**ENGINE SPECIFICATIONS**

**Model:** Caterpillar C6.6.  
**Type:** Six Cylinder, Four Cycle, Turbo-Charged, Charge Air Cooled, Liquid Cooled Diesel Engine.  
**Displacement:** 402.8 Cu. In. (6,6 Liters).  
**Lubrication:** Forced Circulation.  
**Air Cleaner:** Dry Type.  
**Fuel Tank:** 171 U.S. Gals. (684 Liters).  
**Full Load Operating Time:** 15.1 Hrs.  
**Starter:** 12V Electric.  
**Standard Features:** Low Oil Pressure and High Coolant Temperature Safety Shut Down Switches/Indicators. Autostart Instrument Panel Includes: Tachometer, Voltmeter, Hourmeter, Coolant Temperature, Oil Pressure and Fuel Level Displays. Manual/Stop/Auto Key Switch, 10 Amp Fuse, Audible Startup Warning Delay. Muffler w/Guard and Weather Cap. Throttle Control.  
**CATERPILLAR PUBLISHED PERFORMANCE:**  
 Maximum Gross BHP (Intermittent)  
 202 (150,6 kW) @ 2200 RPM



THE GORMAN-RUPP COMPANY • MANSFIELD, OHIO

GORMAN-RUPP OF CANADA LIMITED • ST. THOMAS, ONTARIO, CANADA

www.grpumps.com

Specifications Subject to Change Without Notice

Printed in U.S.A.

**Specification Data**

APPROXIMATE  
DIMENSIONS and WEIGHTS

**NET WEIGHT: 8330 LBS. (3778 KG.)**  
**SHIPPING DIMENSIONS: 1220.7 CU. FT. (34.6 CU. M.)**

SECTION CAT, PAGE 100

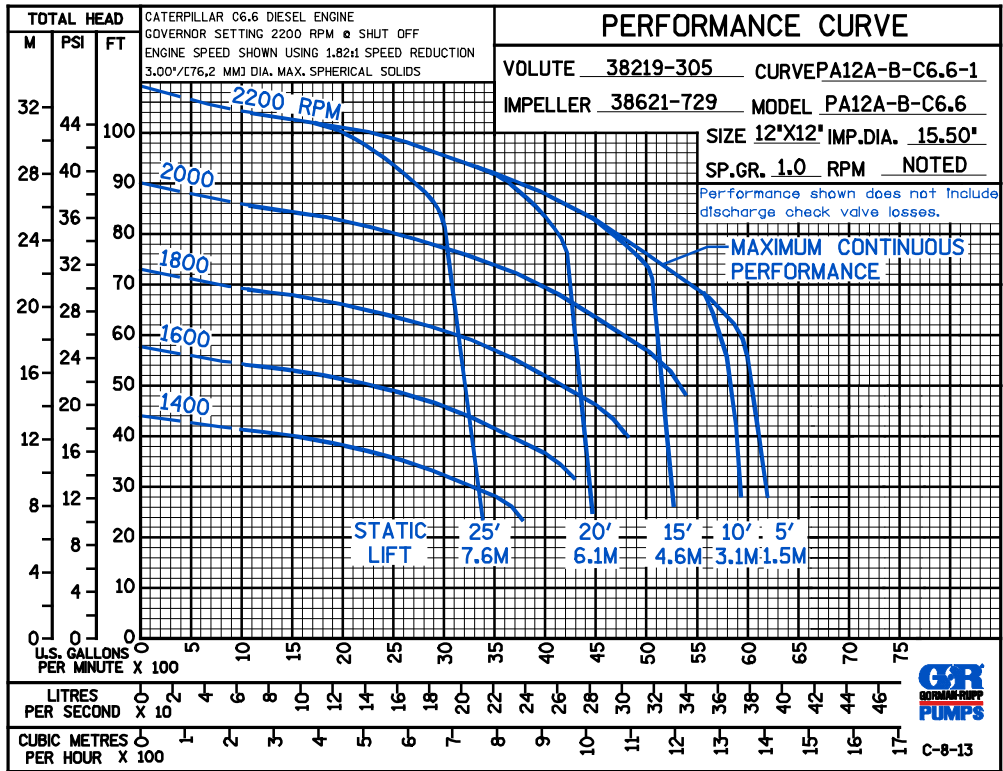
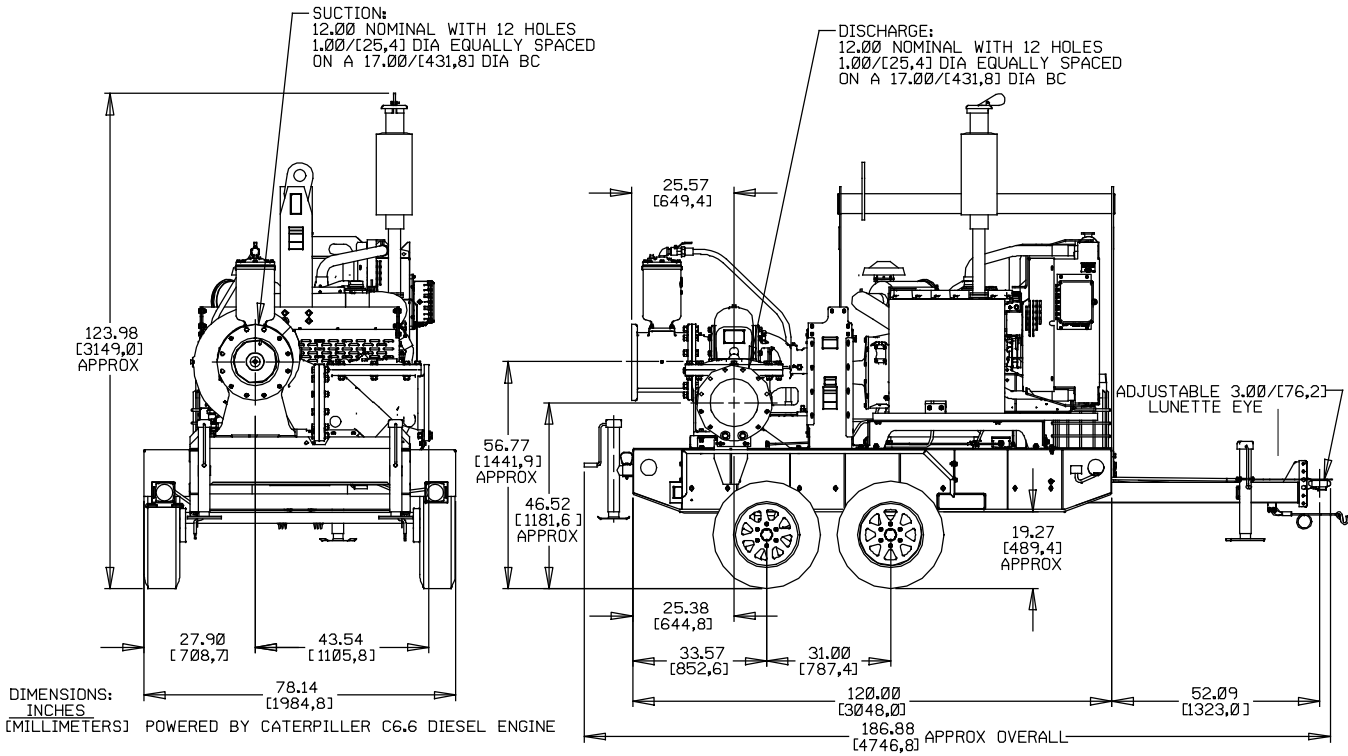

THE GORMAN-RUPP COMPANY • MANSFIELD, OHIO

GORMAN-RUPP OF CANADA LIMITED • ST. THOMAS, ONTARIO, CANADA

Specifications Subject to Change Without Notice

Printed in U.S.A.